



ET Pro² Smart Water Manager™ (SWM) series controllers. Simple, complete and proven smart irrigation ideal for commercial or high end residential customers including home owners associations, commercial campuses, business parks, retail malls, municipal, schools and institutional applications.

Incorporates the exclusive **WeatherTRAK ET Everywhere™** daily hi-resolution weather service. Wireless delivery of local weather data to each controller's built in radio. Simple plug and play for new or retrofit with no local sensors or added phone lines, licensed radio frequencies or cables necessary.

Includes the patented **WeatherTRAK Scheduling Engine™** that allows for customization for each zone of your landscape and takes the guesswork out of irrigation programming. Provides for complete user control to comply with agency regulations as well as site specific customer needs.

WeatherTRAK Central Internet Management - monitor, manage and control your irrigation down to the station level in real time from any internet enabled computer. Purchase controllers as Central or upgrade from Basic communication (one-way) at any time with a simple upgrade kit. Controllers accessible via internet minutes after installation.

Recognized by the **Irrigation Associations SWAT protocol with 100% test scores for efficiency and run-off reduction potential.**

ET Pro² Smart Water Manager Controller

- 12-48 stations with heavy-duty screw-less field wire terminals.
- Station modularity in 6-station increments starting at 12 stations.
- Heavy-duty surge protection up to 6 KV.
- Powder-coated or stainless steel wall mount and pedestal models.
- Interchangeable transformer location makes for easier retrofits.
- Non-volatile memory to store all settings without battery.
- Automatic field wire fault protection and detection.
- Dedicated master valve designated as normally open or closed.
- Dedicated pump start – uses a station output.
- Large 3.0amp transformer – run up to 6 valves simultaneously
- Compatible with 3rd party rain and freeze sensors.
- Built-in held-held remote compatibility w/ RainMaster™ “Pro-Max UA” series with EX-32 cable or TRC™ “Commander” Series.
- Purchase as Central or Upgrade to **Central Internet Management** with a 2-way central kit.
- Flow monitoring built in – directly compatible with Creative Sensor Technology and Data Industrial flow sensors.

ET Pro² Smart Water Manager Programming

- 4 Operating modes per station – Automated with ET, User Program with ET, No ET and Off including 2 start times per program and up to 20 cycles per program.
- Automated cycle and soak.
- Proven WeatherTRAK Scheduling Engine optimizes watering by station specific utilizing plant, soil, sprinkler, slope data.
- Station specific program settings and % adjust control to fine tune watering.
- Automated skip days based on soil moisture depletion levels per zone.
- User defined water days and water windows per program to comply with all agency regulations.
- Run time rationing for plant health protection under constricted water window situations.
- Manual or multi station manual watering from 1-99 minutes.
- Program Review screen by station for current week watering and projected upcoming watering.

ET Pro² Central Internet Management

- Optional Central Internet Management for all Pro² Controllers (purchased as Central or Upgrade from Basic).
- Secure User Name and Password – multi-named users per controller or site.
- Single controller up to 500 controllers per account.
- Instant access at time of installation – program from web for first time, minutes after you install.
- User friendly Dashboard views for quick management and analysis of sites.
- Anytime web-based or field based programming with full real time synchronization.
- Access to all station level and program level settings.
- User-defined names for controllers, programs and stations.
- Email and SMS/Text Alerts; Flow, Hardware, Field Wiring, Program Conflicts, Communication and more.
- Reporting – User customized Runtime, Accumulated ET, Flow – single or multi controller, Alerts, Settings.
- Quick links and sorting feature for custom data views.
- Instant controller shutdown.

WeatherTRAK ET Everywhere™ Weather Service

- Daily ET sent each night.
- Hi Resolution local data for each 1km area across North America.
- Uses real time network of over 40,000 weather stations, satellite data, Doppler radar and more.
- No single weather station reliance or risk.
- Advanced modeling uses hundreds of data points for each ET zone – failsafe with no single point of failure.
- Utilizes industry standard Penman Montheith ET Equation (temperature, wind, solar radiation, humidity) the only methodology recognized by the Irrigation Association for determining ET.
- Redundant weather and communication networks for 99% uptime.

WeatherTRAK Customer Service and Support

- Toll Free Customer Support 6 days/week English/ Spanish.
- On line training.
- On line real time troubleshooting.
- National distribution and sales support.
- WeatherTRAK Professional Services.
- **5 Year Product Warranty.**

Construction

- 16 gauge, wall mount enclosure with key lock entry available in two different finishes (stainless and powder coated).
- UL approved weather-resistant enclosure.
- “Station Keys” allow for increase or decrease in station count in 6-station increments in a matter of seconds.
- Key-hole mounting for wall mount enclosures makes it easy to install.
- Easily adapts to a small 18 gauge pedestal, also available in two different finishes.
- Multiple front entry and top entry VIT StrongBox enclosure options.

Weights and Measures

- Wall Mount Dimensions: (12” W x 17” H x 5-3/4” D) - Shipping weight 21 lbs. Powder-coated or stainless steel options
- Small Pedestal Dimensions: Dimensions: (11-1/4” W x 28” H x 4-1/8” D) - Shipping weight 21 lbs. Powder-coated or stainless steel options
- *VIT Strong Box Stainless Steel Pedestal Enclosures and Retrofit Chassis options available in front and top entry – see catalog for details

Electrical Specifications

- Input Power:
 - 120 VAC +/- 10%, (60 Hz) or 220 VAC +/- 10%, (60 Hz)
 - 0.60 Amps per station output (24 VAC)
- Consumptive Power
 - Idle State: 2.5 Watts Maximum Power Requirements for Irrigation State: 70 Watts
- Station Output Power: 24 VAC (60 Hz)
 - 0.60 Amps per station output (24 VAC) per station max including a pump start
 - 0.80 Amps per station output (24 VAC) master valve
 - 3.0 Amps (80 VA) total load
- UL Approved

ET Pro² Smart Water Manager Specifying Information

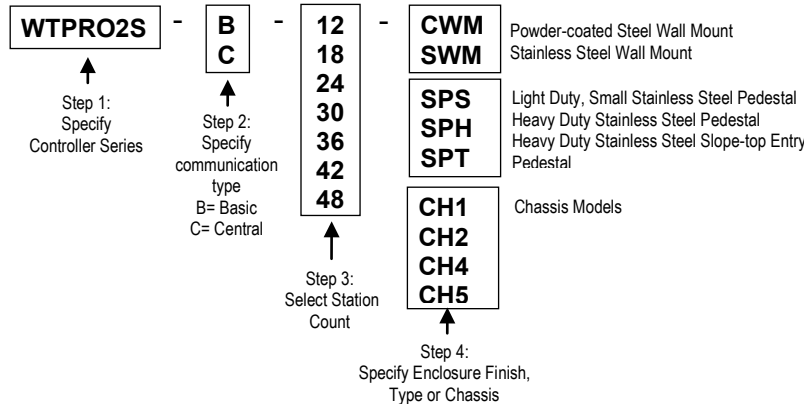

For example: A basic, 18 station, stainless steel wall mount model would be specified as: **WTPRO2S-B-18-SWM**

For example: A central, 18 station powder-coated cold-rolled steel wall mount model with a pedestal would be specified as: **WTPRO2SC-18-CWM** with a **WTPRO2S-CPED**

For example: A central, 24-station, heavy duty stainless steel front entry pedestal would be specified as: **WTPRO2S-C-24-SPH**



**Small Pedestal Model
Stainless Steel or Powder Coated Steel**



**Wall Mount Model
Stainless Steel or Powder Coated Steel**

* See WeatherTRAK Product Catalog for complete line of controllers and enclosures